

Operation Instruction Manual

WSD-1500H-W

Programmable PID Temperature Controller

Version 2.2 (March, 2021)

Auber Instruments

5755 North Point Parkway, Suite 99

Alpharetta, GA 30022

770-569-8420

www.auberins.com

Introduction

Thank you for purchasing the Auber WS series temperature controller. We sincerely appreciate your decision and trust that our machine will meet your expectations in both the quality of the result and the value of our product. While we are delighted that you may be anxious to operate the controller for your project, a few minutes of your time reading through this manual will only serve to enhance your experience in the months and years ahead. In particular, we urge you to read through the safety warnings below. Although this plug-and-play controller is very easy to operate, the process involves high temperature and high wattage appliances and your safety is paramount.



SAFETY WARNINGS

- This controller is designed only to be used with devices that have limited power and their own thermal cut off protection, such as a thermostat or thermal fuse in case of controller failure.
- Do not place any objects on the top of controller surface which is used to vent excess heat during its operation.
- The maximum electric current this controller can handle is 15 ampere. For 120 volt AC in US and Canada, this limits the heater power to 1800 watts.
- Always place the sensor in the controlled subject when the controller is on. Before turning on the controller, please make sure the sensor is placed inside the container to be controlled. Leaving the sensor outside of the solution will form an open loop operation. If the sensor is left outside, controller will assume the temperature is low even if the controlled subject is already very hot. The controller will provide full power to the heater. It will not only overheat the controller, but also damage your appliance, and even cause a fire.
- This controller is designed to control the devices recommended by Auber

Copyright © 2021 Auber Instruments Inc. All rights reserved.

No part of this manual shall be copied, reproduced, or transmitted in any way without the prior, written consent of Auber Instruments.

Auber Instruments retains the exclusive rights to all information included in this document.

Instruments only. Using it to control a not recommended device can be dangerous and cause fire. Auber Instruments is not liable for damages caused by misuse of the controller. If you are not sure the controller can be used, please contact Auber Instruments before use.

- If an abnormal display or noise is observed, turn the controller off, unplug the power cord and contact the manufacturer before using it again.
- Clean the controller only when it is cool and unplugged.
- Do not allow children to operate the controller.

Specifications

Number of storable recipes	6
Number of steps in each recipe	6
Input voltage	US 120V, European 220V, 50/60 Hz
Output voltage	The same as the input.
Maximum Current	15A for 120V AC, 12A for 220V AC, 3A for the smoke generator output.
Controller Mode	PID, PI, PD or P.
Output switching device	Built-in optically isolated solid state relay with zero voltage crossing switching.
Sensor type	PT1000 RTD sensor
Timer range	6 steps with 23h59m for each step.
Temperature resolution	1°C or 1°F.
Temperature display unit	Celsius or Fahrenheit.
Temperature display range	-40 - 400°C, or -40 - 750°F.
Mini. Control Temperature	5°C (9°F) above ambient with smoker generator off, 22°C (40°F) above ambient with smoker generator on.
Max. Control Temperature	300°C (570°F), limited by sensor cable.
Temperature accuracy	+/-1°C
Smoker generator control output maximum current	3A at 120V
Dimension	6 x 3 x 8.3 inch (155 x 80 x 210 mm) W x H x D.
Weight	3.2 lb (1.4 kg).
Warranty	One (1) year for the controller, 90 days for sensors.

Note: This controller has US input plug and output socket that meet the NEMA 5-15 standard. For international order, user can get a converter from local electronics store to convert the connection. For countries that use 220-240VAC power line, the maximum control power of this controller is 2600 Watts.

Operating Instructions

1. Description of the controller



Figure 1. Front Panel.

- 1) **LCD display window** – During normal display mode, it will display temperature readings from all probes and set temperature for cabinet. When high or low limit alarm is triggered, this display will show alarm notification. In time checking mode, it will display time/step information. In cooking profile or parameter setting modes, it will display the step/parameter name and its value. For details, please check section 3.
- 2) **Alarm status/smoke generator indicator (Red)**– This indicator has two functions. When this indicator is blinking, temperature alarm is triggered. The LCD display will flash the alarm notification at same time. When this indicator is solid ON, the smoke generator control output is activated.
- 3) **Output status indicator (Green)**- This LED indicates the output status that should be synchronized with heater. When this indicator is ON, the heater is powered. When it is OFF, the heater's power is off. When it is flashing, it means the heater is on and off intermittently to reduce the power output. It is synchronized with the power light on the cooking device.
- 4) **Wi-Fi status indicator (Blue)** – It indicates the Wi-Fi connection status of the controller. Solid ON: the controller is connected to the internet. Fast flashing: Wi-Fi

module is ready for configuration. Slow flashing: Wi-Fi module is initializing its connection to the router. Off: no Wi-Fi connection.

- 5) **SET Key** – Press momentarily to enter the cooking profile settings. Press and hold about 2 seconds to enter parameter settings. This key can also be used to confirm the change of setting.
- 6) **Time/Back Key** – Pressing this key in normal operation mode will display time checking mode. Pressing this key in the parameter setting mode will return back to the upper level menu, or exit.
- 7) **Down Key** – Decrease value, scroll down the menu, or mute the buzzer.
- 8) **Up Key** – Increase value, scroll up the menu, or mute the buzzer.

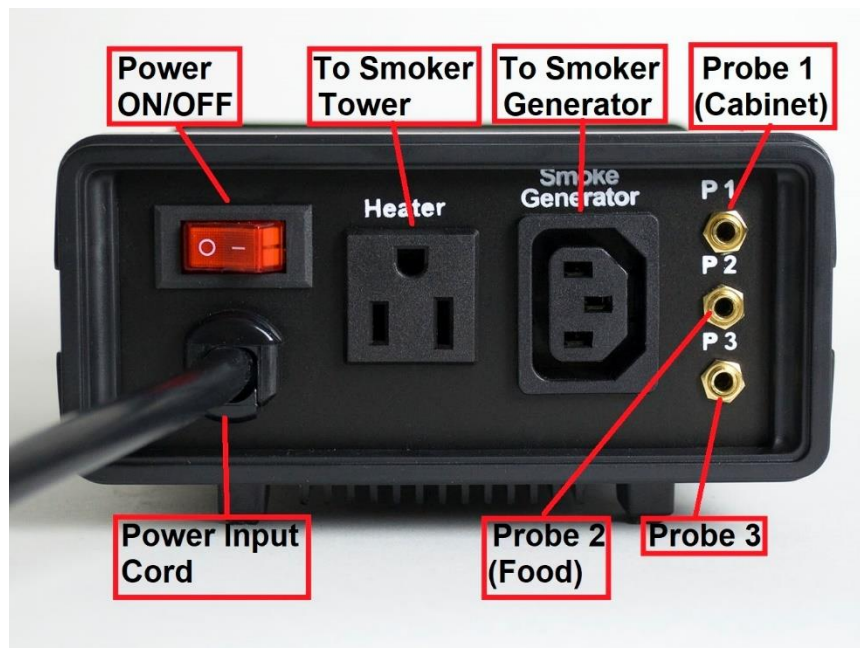

Figure 2. Back Panel.

Up to three temperature probes can be used with this controller, and they need to be plugged in P1, P2 and P3 sockets on the right of the back panel. P1 socket is for cabinet temperature probe (Probe 1); P2 socket is for food internal probe (Probe 2); P3 socket is for 3rd temperature probe (Probe 3).

2. Connecting this controller to your smoker

Install the sensor.

(Note: If you ordered wall mount sensor instead of free hanging sensor, please see the separate instruction for wall mount sensor installation.)

The controller is supplied with two probes by default. The one with the short tip is for measuring the cabinet temperature (Probe 1). It needs to be plugged to the top sensor jack at the back of the controller. The long probe with a bend at the end is for the meat

internal temperature measurement (Probe 2). It needs to be plugged to the bottom sensor jack at the back of the controller. The tips of the probes are dropped into the damper hole. Place a piece of tape on the top of the smoker tower to hold them in place. The tip of Probe 1 should be placed close to the food but high enough so that it does not touch the food. (See Figure 3). The tip of Probe 2 is to be inserted into the meat.

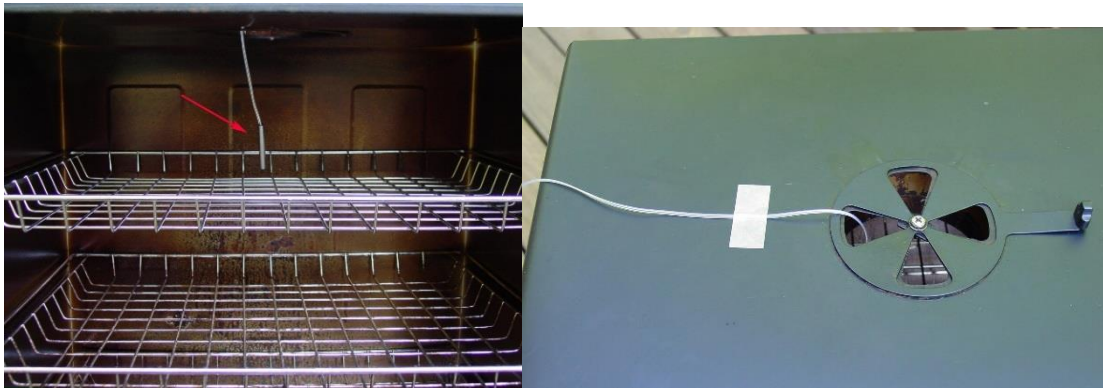

Figure 3. Sensor position. Left, the sensor should be placed close to the food but high enough so that it does not touch the food. Right, hold the sensor in place by a piece of tape.

For the “Original” and Stainless Steel Bradley smoker, the Temperature Heat Control Switch on the smoker tower should be set to the Hi position (most right).

There are several ways to connect the controller and Bradley Smoker.

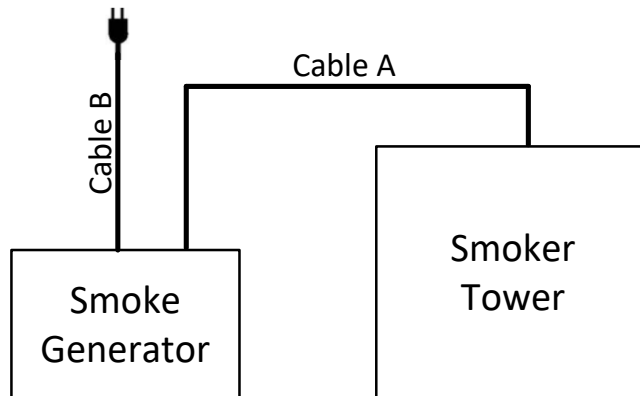

Figure 3.1 Power Cable wiring for Original Bradley Smoker

Cable A: Power cable for Smoker Tower, C14 plug

Cable B: Power cable for smoke generator, NEMA5-15P plug

1) Connection for Bradley Original Smoker, with control of the smoker generator.

a) Connecting the controller to the power outlet, you should use the power cord that came with the Bradley Smoker for connecting the smoker generator to the power outlet.

b) Connecting the controller to the smoker generator. You should use the power cord that originally was used for connection between the smoker generator and smoker tower.



Figure 4. Connection between the controller and Bradley Original Smoke generator.

c) Connecting the controller output to the Bradley Smoker Tower with the power cord that came with the Auber Controller

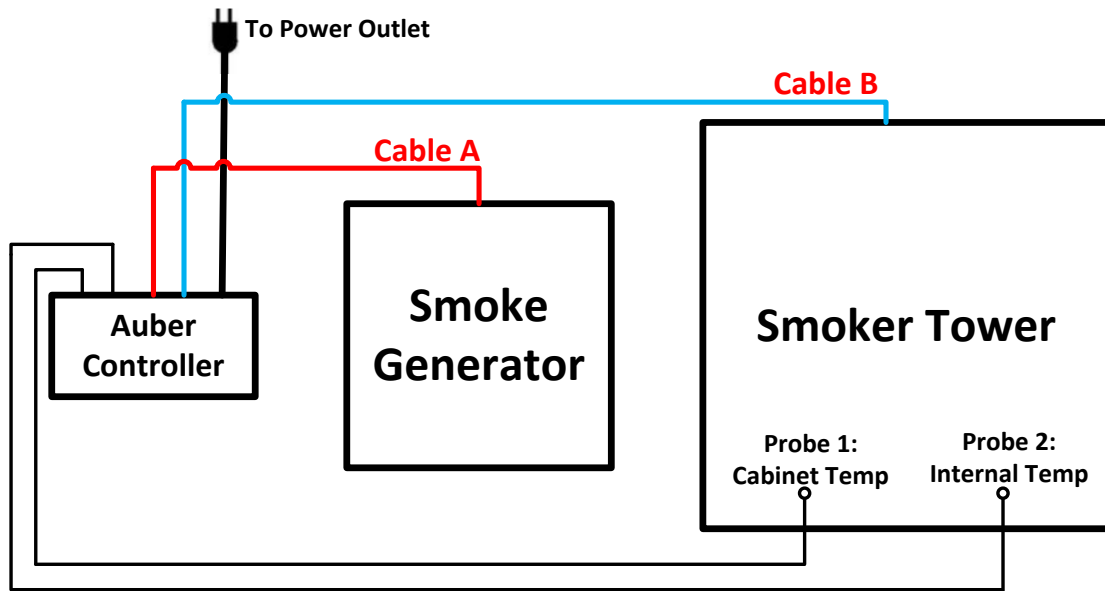

Figure 5. Diagram

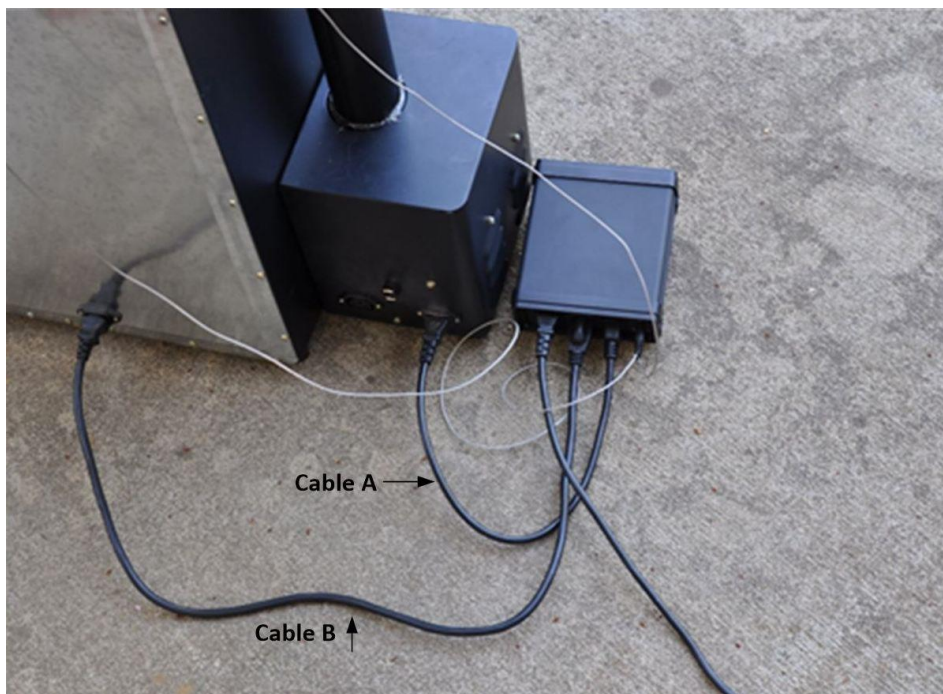

Figure 6. Back view



Figure 7. Connection between the controller and smoker

2) Connection for Bradley Digital Smoker.

For the Bradley Digital Smoker, both controller and smoker generator should be connected directly to the wall outlet. Connect the controller output with the smoker tower.

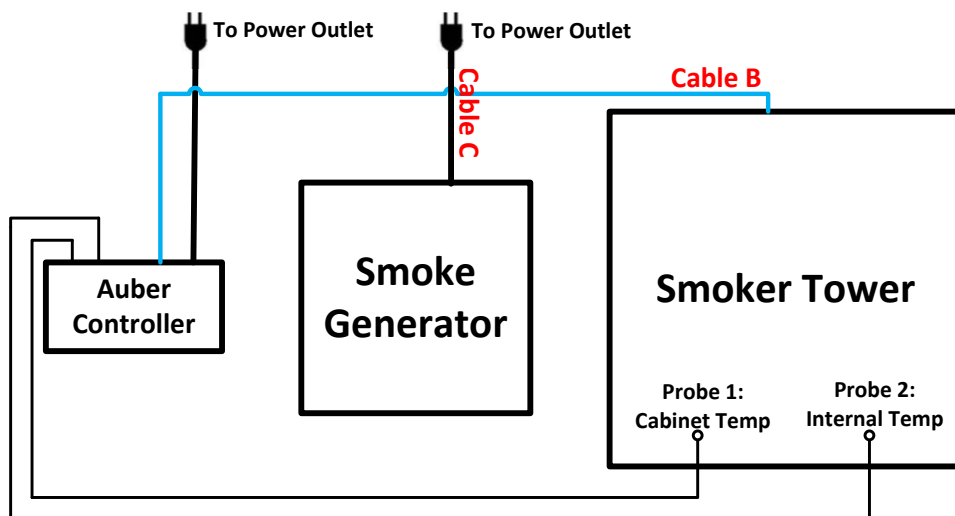

Figure 8. Connection for Bradley Digital Smoker
Cable C is extra 18 AWG power cord, same as Cable B

3. Display modes

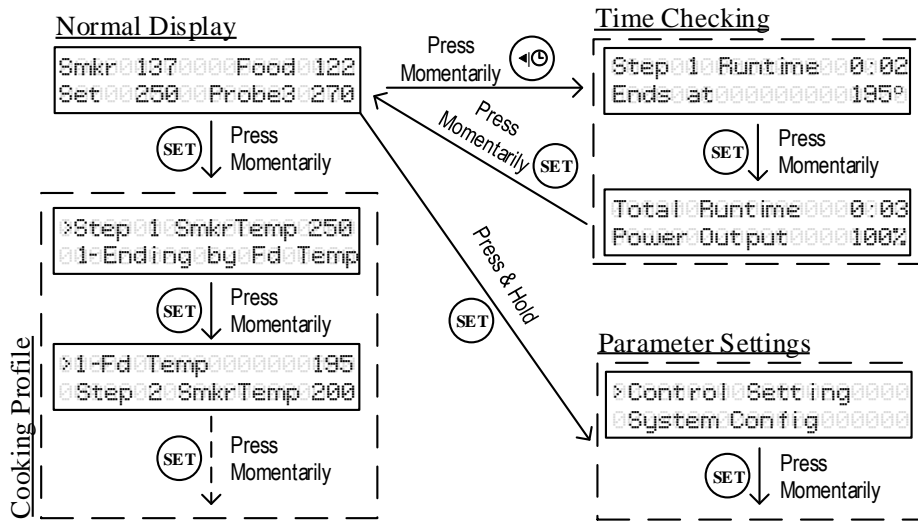

Figure 9. Switching between different display modes

Four display modes are available: 1) Normal display, 2) Time Checking, 3) Cooking Profile and 4) Parameter setting.

When you turn on the controller, it will show the initializing display for several seconds. it will display controller's name and firmware version during this period. Then it will show the normal mode display.



Figure 10. Initializing display. Top line is for model number. Bottom line is for firmware version.

3.1 Normal display mode

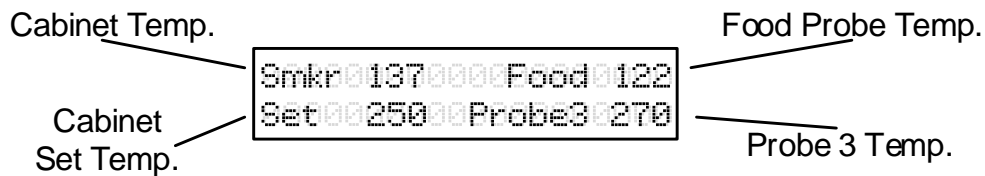

Figure 11-1. Information displayed in normal display mode (Default)

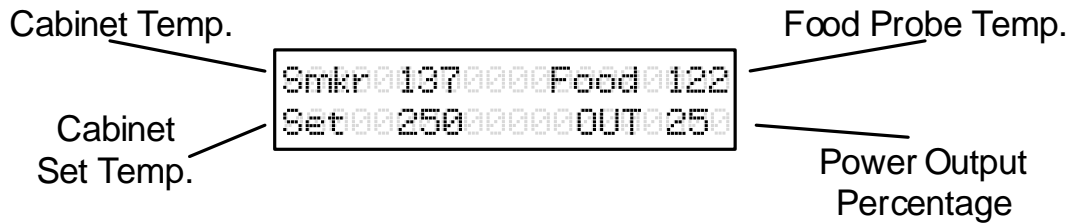

Figure 11-2. Information displayed in normal display mode
(when probe 3 is disabled in the setting, note 16 in section 7.2)

3.2 Time checking mode

To check current running status (status check mode), press Timer Key momentarily. Press Time Key again to display more information, or return back to normal display mode. Three display possibilities:

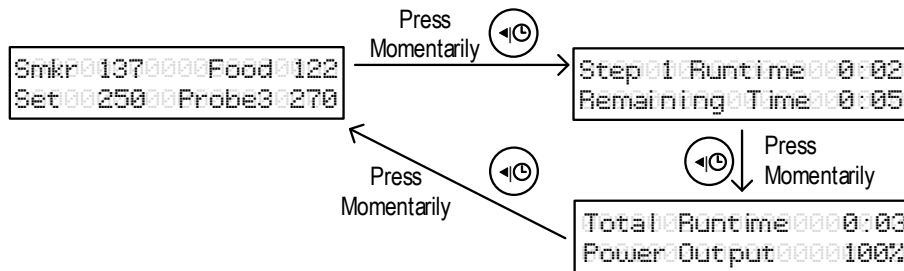

Figure 12. Time checking mode when current step is ended by time (multi-step mode).

Display #1 (if current step is ended by time): In normal mode, press timer key momentarily to display the elapsed time for current step (top) and remaining time for current step (bottom). Press timer key again to display the total running time after you recently powered up the controller (top), and current power output percentage. Press timer key again to return to normal display mode.

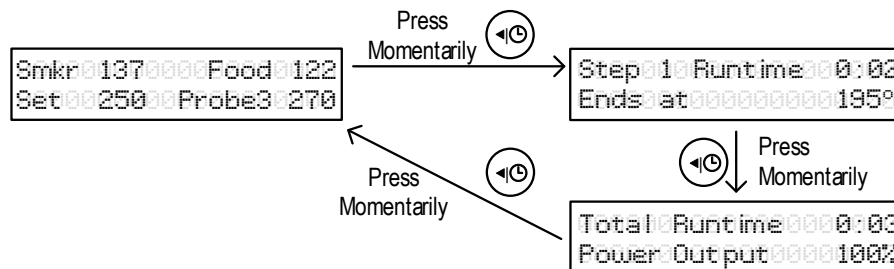

Figure 13. Time checking mode when current step is ended by food temperature (multi-step mode).

Display #2 (if current step is ended by food temperature): In normal mode, press timer key momentarily to display the elapsed time for current step (top) and food probe ending temperature (bottom). Press timer key again to display the total running time

after you recently powered up the controller (top), and current power output percentage. Press timer key again to return to normal display mode.



Figure 14. Time checking mode when single step mode.

Display #3 (if single step mode): Press timer key to display the total running time after you recently powered up the controller (top), and current power output percentage. Press timer key again to return to normal display mode.

3.3 Cooking profile programming mode

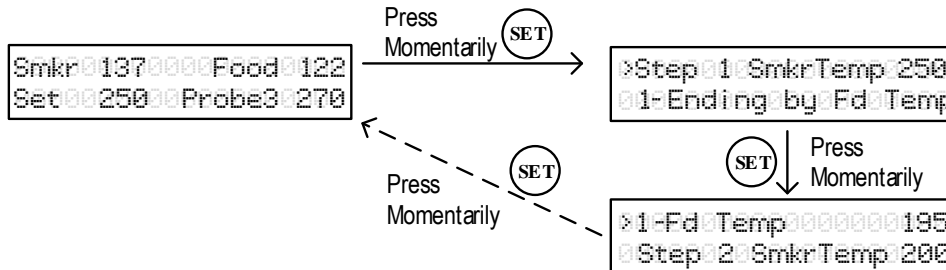

Figure 15. Access the menu of cooking profile mode using SET key.

Press SET key momentarily to enter cooking profile mode. For details, please check section 4.1.

3.4 Parameter setting mode

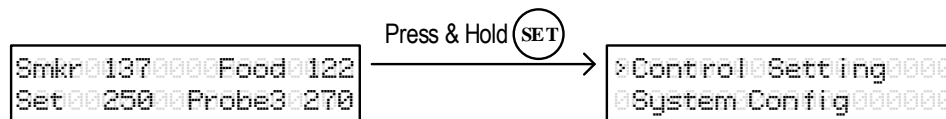

Figure 16. Access the menu of parameter setting mode using SET key.

Press and hold SET key for about 2s to enter parameter setting mode. For details, please check section 5.

4. Operation

All cooking profile settings and control parameters can be accessed both from the device and from AuberSmart app.

4.1 Set the Cooking Profile

The controller's cooking profile can be either set to multi-step mode (default) or single-step mode. In the multi-step mode, up to 6 steps can be programmed. Each step has its own set temperature for cabinet probe (Probe 1), and its step-ending criterion. A cooking step can either end by timer or by food internal temperature (Probe 2). In the single-step mode, the controller will try to maintain the cabinet temperature at the set value of Step 1 ("Step 1 SmkrTemp") as long as the controller is on. To switch between single-step mode and multi-step mode, please check section 4.1.3.

4.1.1 Multi-Step Mode

A total of 6 steps can be programmed on this controller. Each program step comprises a target temperature of cabinet (shown as "SmkrTemp: XXX") and an ending criterion setting "**X-Ending**", where "X" is the step number. For example, "**1-Ending**" means the ending criterion of **Step 1**. The "ending criterion" is a new concept to people who never used Auber's controllers. It determines how a cooking step is considered finished. Two options are available: time and food internal temperature (Probe 2). If you want **Step X** to be ended after a pre-set time period, set "**X-Ending**" by "**Time**"; if you want **Step X** to be ended when food internal temperature reaches a pre-set value, set "**X-Ending**" to "**Fd Temp**".

After you set "**X-Ending**" to "**Time**", you will need to set "**X-Time**". Here, "**X-Time**" is defined as the time duration (in hh:mm format) of the current step. The timer will start counting even if the cabinet temperature has not yet reached the target cabinet temperature. So, please make sure that the step time is long enough. If the step time is too short, the controller may continue to the next step no matter what the actually cabinet temperature is. If you set "**X-Ending**" to "**X-Fd Temp**", you will need to set "**X-Fd Temp**" to the desired food temperature (Probe 2), but only one setting is relevant to the current cooking step depending on the **X-Ending** setting (either **X-Time** or **X-Fd Temp**).

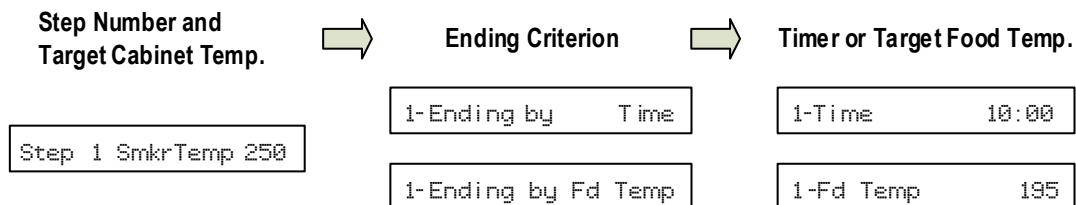

Figure 17. For each cooking step, set the target cabinet temperature, ending criterion, and timer or target food temperature.

If "**X-Ending**" of a certain step is set to "**Fd Temp**" while the food probe (Probe 2) is not plugged in, this step will never end. Cabinet probe (Probe 1) should always be plugged in, otherwise controller will stop sending power to the heater as protection. When all of

the “**X-Ending**” are set to time, the controller can operate with only the cabinet probe (Probe 1) plugged in.

Note: user can also use Aubersmart app to view and change both time and food temperature of each step.

Cooking Profile Example

Table 1. example program

Step Number	Cabinet Temp. (SmkrTemp)	X-Ending (Ending)	Time/ Fd Temp
1	120	Time	2:00
2	190	Fd Temp	160
3	130	Time	20:00
4	0	Time	0:0
5	0	Time	0:0
6	0	Time	0:0

The example program for the controller is listed in Table 1. This program will control the temperature of the cabinet at 120°F for 2 hours. Then, change the temperature to 190°F. It will stay at 190°F until internal temperature of the meat reaches 160°F. Then, the controller will drop the temperature to 130°F for 20 hours, waiting you to pick the food. If you change set temperature in step 3 (Step 3 SmkrTemp) to 0 and time for step 3 to 0, when food internal temperature reaches 160°F, the controller will shut off the heater and stop the program. it will give beeping sound until the buzzer is muted or the power input has been reset.

A flow chart of how to enter the cooking profile is shown in Figure 18. To start program the cooking profile, press SET key shortly to enter the Cooking Profile Programming mode. The top line in the display shows the step number “Step: 1” and the current target of cabinet temperature “SmkrTemp 250”. To enter or edit the profile:

- 1) Use ▲ or ▼ key to move the cursor “>” to the parameter you want to edit.
- 2) Press SET key, the value to be edited should start blinking.
- 3) Use ▲ or ▼ arrow key to edit the value.
- 4) Then press SET key again to save the change. That parameter will stop blinking.
- 5) Use ▲ or ▼ key to go another parameter, repeat the previous operations till you have finished entering all the cooking steps.

Note: New setting will NOT be saved if SET key is not pressed. After programming the necessary steps for cooking, you can finish programming by pressing the Time/Back key

to exit the menu. Or, you can use ▲ or ▼ key to go to “Back”, and press SET key to exit. The display can also return to the normal display mode if no key is pressed in about 15 seconds.

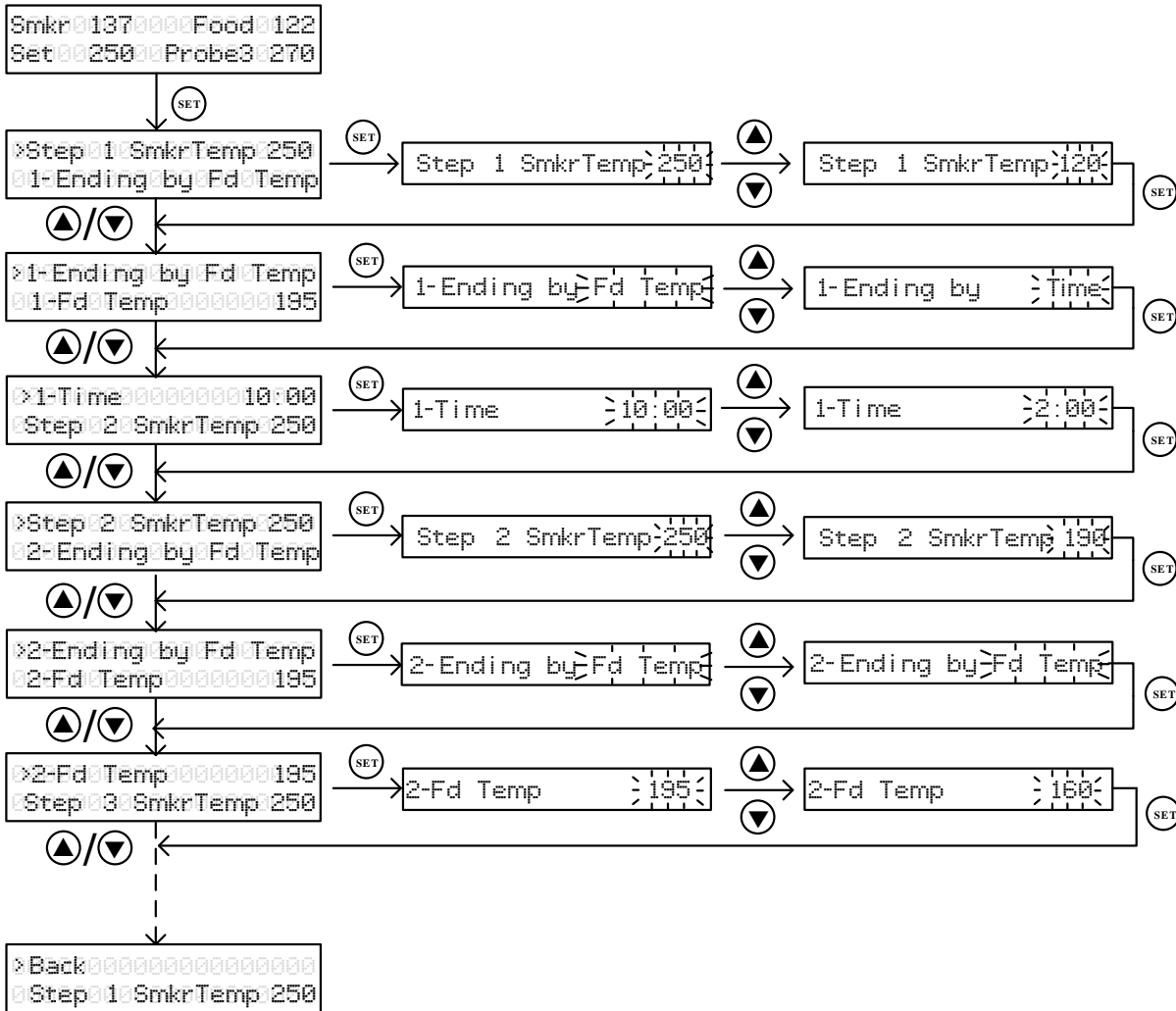

Figure 18. How to enter a cooking profile.

The example program in table 1 is used in this flow chart as a demo.

4.1.2 Single-Step Mode

In single-step mode, you can only access and change the target cabinet temperature of Step 1 from the device. The controller will try to maintain the smoker temperature at the set temperature (Smkr Temp) of Step 1 continuously as long as the controller is powered on. If this controller is powered off and turned back on again, it will resume operating in this mode. You can still view and change settings in other steps in Cooking Profile on the Aubersmart app, but they don't apply to this mode.

To change the set temperature in single-step mode, press SET key once, it will show

“Step: 1” and the current target cabinet temperature in the top line. A cursor “>” will be shown on the left indicating which line will be selected. Press SET key once, the current set temperature should start blinking. Use ▲ and ▼ keys to change the set temperature. When finished, press the SET again to confirm the change. That number will stop blinking. Press the Timer/Back key to exit the menu. Or use ▲ or ▼ key to scroll to “Back” and then press SET key to exit. The display will return to the normal display mode if no key is pressed in 15 seconds.

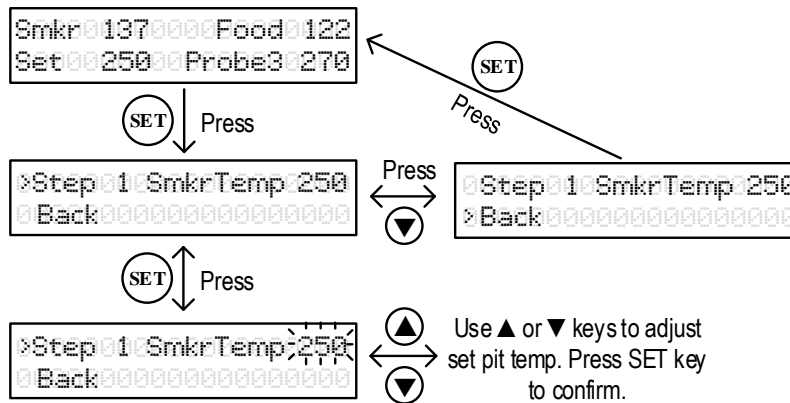

Figure 19. How to change the set temperature in single-step mode.

4.1.3 Program Status & Control (for firmware version 1.7.4 or newer)

User can check or change current program running status by this parameter. It can be used to stop/start the program, or jump to a different step. This parameter is under the Cooking Profile menu as stated in section 4.1. Parameter name showing on the controller’s display is **Prog Status**. Available options for this parameter are: Stop, Start, Step 1 ~ 6, Back.

When pressing SET button momentarily to enter Cooking Profile menu, it will display **Prog Status** on the left top, and current step number or stopped status on the right top. Press SET button again, then user can change its options to start/stop the program or jump steps. Press SET button again to confirm the change. See option definition and flow chart below.

Option definition:

Stop: Stop the current cooking program.

Start: Start the cooking program from Step 1.

Step 1 ~ 6: Jump to specific step. For example, if user selects Step 3, controller will skip Step 1 & 2, and run rest steps starting at Step 3. If the controller program is stopped, selecting those options will also exit stopped mode. Step 1 ~ 6 options are available for multi-step mode only. For single-step mode, only **Step 1** is available.

Back: Go back to upper level. Parameter is unchanged.

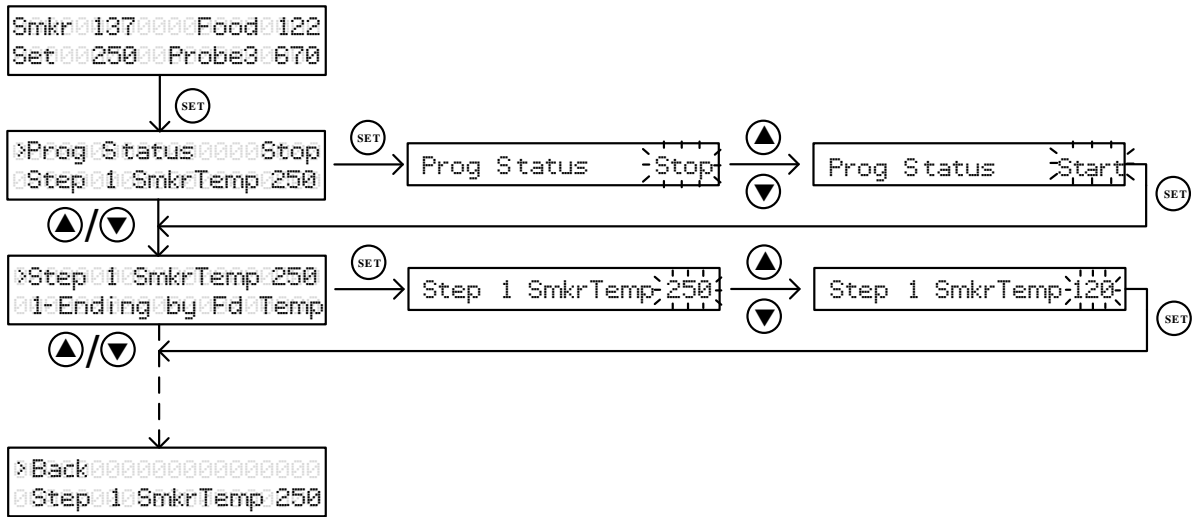

Figure 18A. Flow chart of how to use Program Status & Control function.

4.1.4 Switch between single-step mode and multi-step mode

To switch between single-step mode and multi-step mode, go to Parameter Setting mode by holding the SET key, and then go to “**System Config**” menu, find parameter “**Program Mode**”, then change it to “**ON**” (for multi-step mode) or “**OFF**” (for single-step mode). By default, the controller is set to multi-step mode “**ON**”. Please see the flow chart in Figure 20 for how to access this parameter from the controller.

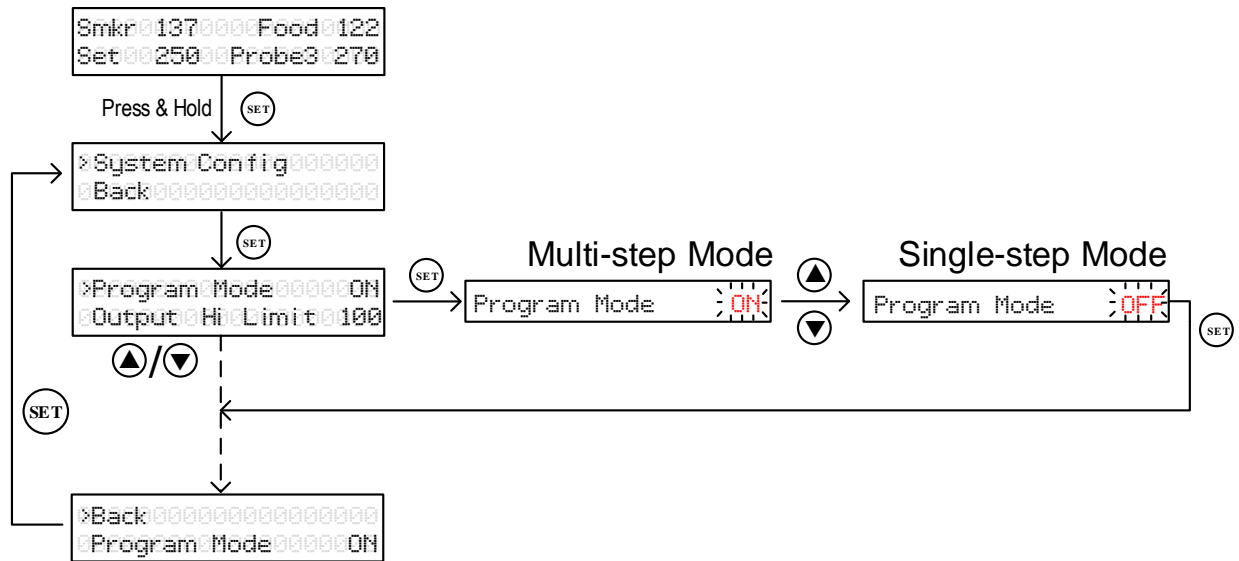

Figure 20. How to switch between programmable mode and single-step mode

5. Controller parameter setup.

To access the parameters, press and hold SET key for about 2 seconds. Parameters are divided into two groups: “**Control Config**” and “**System Config**”.

7.1 Control Configurations

Parameters related control configurations during the smoking process are listed under “Control Config” menu. **Error! Reference source not found.** shows the list of **these parameters, their range and initial set value when left the factory.** The flow chart in Figure 21 shows the operations of accessing and adjusting the parameters in “Control Config”.

Table 2. Parameters in Control Config menu.

Name	Description	Range	Initial	Note
Smkr Hi Alarm	Cabinet Probe High Alarm (Probe 1)	0 - 750	350	1
Smkr Lo Alarm	Cabinet Probe Low Alarm (Probe 1)	0 - 750	50	2
Food Hi Alarm	Food Probe High Alarm (Probe 2)	0 - 650	350	3
Probe3 Hi Alarm	Probe 3 High Alarm	0 - 650	300	4
Relay Action	Smoke Generator Relay Setting	0 - 63	0	5
P (Proportional)	Proportional Constant	1 - 999	7	6
I (Integral)	Integral Time	0 - 9999	600	7
D (Derivative)	Derivative Time	0 - 999	150	8
T (Cycle Time)	Control Cycle Time	2 - 200	2	9
Auto-tune	Auto-tune	ON, OFF	OFF	10
Save Recipe	Save Recipe Settings	Back, B1, B2, C1, C2, F1, F2	Back	11
Recall Recipe	Recall Recipe Settings	Back, B1, B2, C1, C2, F1, F2	Back	11
Back	Back to Upper Level Menu			

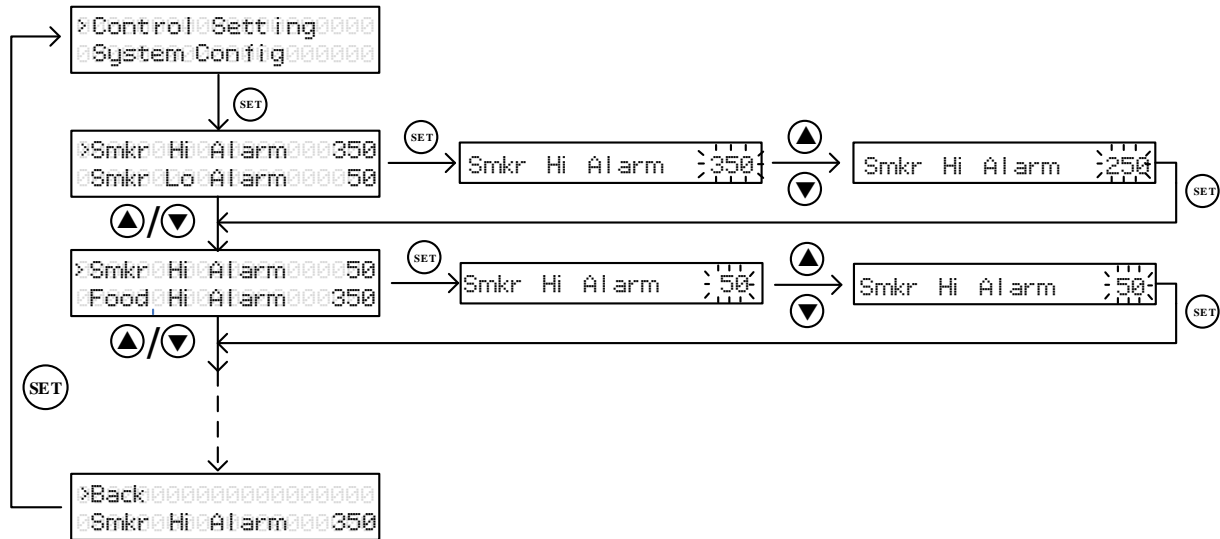

Figure 21. Access the parameters in Control Config menu.

Note 1. Smkr Hi Alarm: This is the high temperature alarm for cabinet temperature (Probe 1). When cabinet probe reading is higher than **Smkr Hi Alarm**, the buzzer on the controller will go off and the LCD display will flash between the normal display and the alarm display showing in Figure 22. The alarm has 1 degree hysteresis. The user can mute the buzzer by pressing either the Up key or the Down key. Temperature must move out of the hysteresis zone to activate the alarm again. For example, if **Smkr Hi Alarm** is set to 290°F, the buzzer will go off when Probe 1 reads higher than 291°F, and the buzzer will stop when Probe 1 reads lower than 289°F. To disable **Smkr Hi Alarm** alarm, you can set it to a large number, such as 750°F.



Figure 22. The LCD display when **Smkr Hi Alarm** is triggered.

Note 2. Smkr Lo Alarm: This is the low temperature alarm for cabinet temperature probe (Probe 1). When cabinet probe reading is lower than **Smkr Lo Alarm**, the buzzer on the controller will go off and the LCD display will flash between the normal display and the alarm display showing in Figure 23. The alarm has 1 degree hysteresis. The user can mute the buzzer by pressing either the Up key or the Down key. Temperature must move out of the hysteresis zone to activate the alarm again. For example, if **Smkr Lo Alarm** is set to 180°F. The buzzer will go off when cabinet temperature drops to 179°F; it will stop when temperature rise above 181°F. The **Smkr Lo Alarm** is suppressed when the controller is just powered up. It will be activated when the cabinet temperature has reached the target cabinet temperature. To disable

the **Smkr Lo Alarm**, you can set it to a small number, such as 0°F (default).



Figure 23. The LCD display when **Smkr Lo Alarm** is triggered.

Note 3. Food Hi Alarm: This is the high temperature alarm for the food internal probe (Probe 2). When food probe reading is higher than **Food Hi Alarm**, the buzzer on the controller will go off and the LCD display will flash between the normal display and the alarm display showing in Figure 24. The alarm has 1 degree hysteresis. The user can mute the buzzer by pressing either the Up key or the Down key. For example, if **Food Hi Alarm** is set to 130°F, the buzzer will go off when Probe 2 reads 131°F, and the buzzer will stop when Probe 2 reads 129°F or lower. To disable **Food Hi Alarm**, you can set it to a large number, such as 650°F.

When smoking multiple pieces of meat of different sizes or thickness, you can put the probe in the thinnest piece first. Set the **Food Hi Alarm** to the temperature when meat is ready. It will let you know when it is done. Then, you can move the probe to the second thinnest pieces and so on. To use this feature, you can set the ending criterion to time. If you prefer to set the ending criterion to food temperature, then the Food Temp should be set to higher than **Food Hi Alarm**.

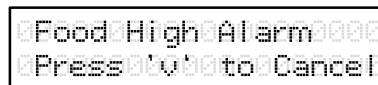

Figure 24. The LCD display when **Food Hi Alarm** is triggered.

Note 4. Probe3 Hi Alarm: This is the high temperature alarm for probe 3. When food probe 3 reading is higher than **Probe3 Hi Alarm**, the buzzer on the controller will go off and the LCD display will flash between the normal display and the alarm display showing in Figure 25. The alarm has 1 degree hysteresis. The user can mute the buzzer by pressing either the Up key or the Down key. For example, if **Probe3 Hi Alarm** is set to 130°F, the buzzer will go off when Probe 3 reads 131°F, and the buzzer will stop when Probe 3 reads 129°F or lower. To disable **Probe3 Hi Alarm**, you can set it to a large number, such as 650°F.

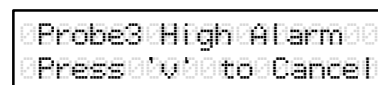

Figure 25. The LCD display when **Probe3 Hi Alarm** is triggered.

Note 5. Relay Action (for Multi-Step Mode Only*): This is smoke generator relay setting. This parameter determines which steps to turn on smoke generator output. Its configuration range is from 0 to 63. It is determined by the following formula:

$$\text{Relay Action} = A * 1 + B * 2 + C * 4 + D * 8 + E * 16 + F * 32;$$

- If A = 0, smoke generator output is OFF at Step 1.
- If A = 1, smoke generator output is ON at Step 1.
- If B = 0, smoke generator output is OFF at Step 2
- If B = 1, smoke generator output is ON at Step 2.
- If C = 0, smoke generator output is OFF at Step 3.
- If C = 1, smoke generator output is ON at Step 3.
- If D = 0, smoke generator output is OFF at Step 4.
- If D = 1, smoke generator output is ON at Step 4.
- If E = 0, smoke generator output is OFF at Step 5.
- If E = 1, smoke generator output is ON at Step 5.
- If F = 0, smoke generator output is OFF at Step 6.
- If F = 1, smoke generator output is ON at Step 6.

Example:

To turn on smoke generator output on step 2 and step 3 only, this parameter needs to be set to 6. ($0 * 1 + 1 * 2 + 1 * 4 + 0 * 8 + 0 * 16 + 0 * 32 = 6.$)

To turn on smoke generator output on step 1 only, set this parameter to 1.

*: This parameter is only available for multi-step mode (Program Mode = ON). For single step mode (Program Mode = OFF), this parameter can still be adjusted but it is not in use. Smoke generator output is disabled in single step mode. To use smoke generator in single step mode, user need an extra power cord to power up the smoke generator separately from this controller.

Note 6. P: Proportional Constant. The unit is 1 degree. This parameter controls the output of the controller based on the difference between the measured and set temperature. Larger the P number means the weaker the action (lower gain). If P = 7, the proportional band is 7 degree. When the sensor temperature is 7 degrees below the proportional band (10 degrees below the setting), the controller will have 100% output. When the temperature is 5 degree below the set point, the output is 71%. When the temperature is equal to the setting, the controller will have 0% output (assuming integral and derivative functions are turned off). This constant also affects both integral and derivative action. Smaller P values will make the both integral and derivative action stronger. Please note the value of the P is temperature unit sensitive. If you found an optimized P value when operating the controller in Fahrenheit, to use in Celsius, that optimized P value needs to

be divided by 1.8. This controller will automatically convert the current P value if you change the temperature display unit.

Note 7. I: Integral Time. The unit is in seconds. This parameter controls the output of controller based on the difference between the measured and set temperature integrated with time. For example, if $I = 1000$, it means if the temperature difference between the cabinet temperature and set temperature stays constant, the output will be doubled after 1000 seconds. Integral action is used to eliminate temperature offset. Larger number means slower action. E.g. assuming the difference between the measured and set temperature is 2 degrees and remain unchanged, the output will increase continuously with time until it reaches 100%. When temperature fluctuate regularly (system oscillating), increase the integral time. Decrease it if the controller is taking too long to eliminate the temperature offset. When $I = 0$, the system becomes a PD controller. For very slow response system such as slow cooker and large commercial rice cooker, set $I = 0$ will significantly reduce the temperature overshoot.

Note 8. d: Derivative Time. The unit is in seconds. Derivative action contributes the output power based on the rate of temperature change. Derivative action can be used to minimize the temperature overshoot by responding its rate of change. The larger the number is, the stronger the action will be. For example, when the door of oven is opened, the temperature will drop at very high rate. The derivative action changes the controller output based on the rate of change rather than the net amount of change. This will allow the controller to act sooner. It will turn the heater to full power before the temperature drops too much.

Note 9. T: Control Cycle Time. The unit is second. This unit determines how long for the controller to calculate each action. e.g. If T is set to 10 seconds, when controller decide the output should be 10%, it will turn on the heater 1 second for every 10 seconds. This parameter should be set at 2 second for heating with an electric heater.

Note 10. Auto-tune: This parameter can be used to initial the auto-tune process. Set Auto-tune to ON then press SET key to confirm. Once exit (in normal display mode), the display will flash alternately between normal display and auto-tune notification (Auto-tuning Please wait...), which indicates auto-tuning is in progress. When the display stops flashing, the auto-tuning process is finished. Now, the newly calculated PID parameters are set and are used for the system. The new parameters will store in the memory even the power is off. To cancel the current auto-tuning process, please set this parameter to OFF. For more information about auto-tune, please see section 10.

Note 11. Save & Recall Recipes: This controller can save up to 6 pieces of smoking recipe (programs). Each recipe file can have up to 6 steps (C-1 to C-6). For convenience,

7.2 System Configurations

Parameters related device configurations which are not often used during the smoking process are listed under “**System Config**” menu. Details of each parameters are listed in Table 3. The flow chart in Figure 27 shows the operations of accessing and adjusting the parameters in “**System Config**”.

Table 3. Parameters in System Config menu.

Name	Description	Range	Initial	Note
Program Mode	Multi-Step Program	ON, OFF	ON	12
Output Hi Limit	Output High Limit %	0 - 100	100	13
Output Lo Limit	Output Low Limit %	0 - 100	0	13
Temp Unit	Temp Unit (°C or °F)	C, F	F	14
Probe1 Offset	Probe 1 (Cabinet Probe) Offset	-9 - 99	0	15
Probe2 Offset	Probe 2 (Food Internal Probe) Offset	-9 - 99	0	15
Probe3 Offset	Probe 3 Offset	-9 - 99	0	15
Probe3 Enabled	Probe 3 Readout Option	Yes, No	Yes	16
P3 ALM-TYPE	Probe 3 Alarm Type Option	ABS, DEV	ABS	17
P3 ALM-CTL	Probe 3 Alarm Output Control Option	ALM, OUT-PAU, BOTH	ALM	18
Step End Alarm	Step Ending Alarm	ON, OFF	ON	19
Backlight Level	LCD Backlight Level	0 - 10	10	20
BUZZ	Built-in Buzzer Option	ON, OFF	ON	21
Data Interval	Data Logging Sampling Interval (App)	1min - 5min	1min	22
nFit	Power Line Digital Filter	Auto, A, B	Auto	23
Password	Device Access Password (App)	100 - 999	777	24
Factory Reset	Factory Reset	Yes, No	No	25
Back	Back to Upper Level Menu			

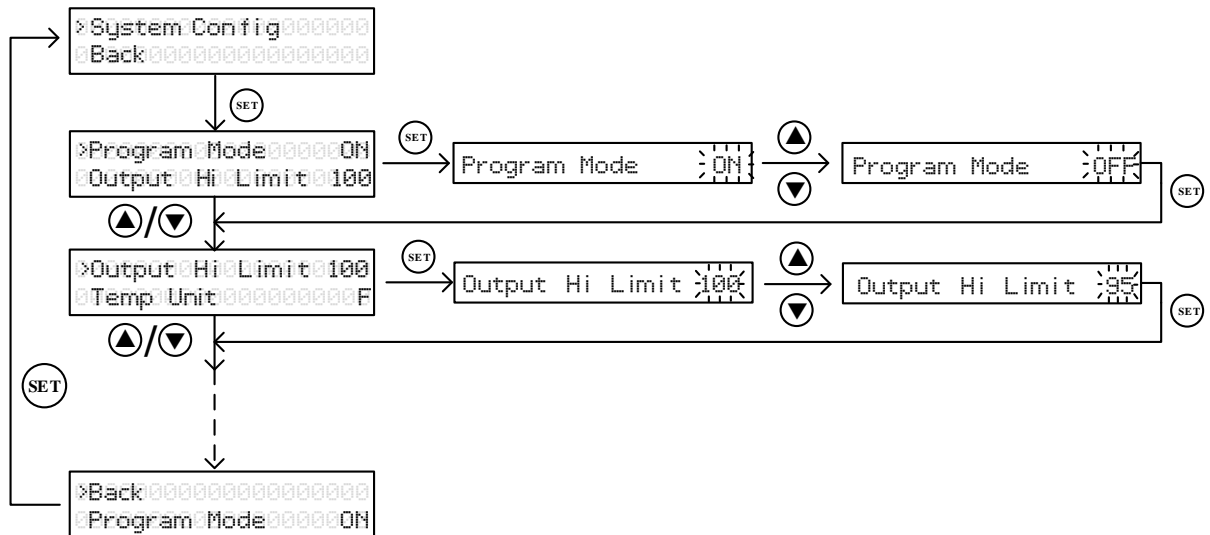

Figure 27. Access the parameters in System Config menu.

Note 12. Program Mode: Multi-step program switch. By default, this controller is set to multi-step mode, and this parameter is set to “ON”. If you want to change it to single-step mode, please change this parameter to “OFF”. For details regarding multi-step mode, please check section 4.1.3

Note 13. Output Hi/Lo Limit: It is expressed as a percentage value. This function will allow you to control the maximum and minimum output power delivered by the heater. For example, if you set **Output Hi Limit** = 50 and your heater is 1000 watts, the output will use 50% of the 1000 watts as the full output. It thinks the 1000W heater as a 500W heater. When the PID algorithm determines 50% output value, the actual power output will be 250 watts. This function can be used in two situations.

1) When you have a very powerful heater and using a very small pot of water to cook at very low temperature, for example, a 1400 watts heater with a one liter (1 qt) pot of water at 130°F. The heater is too powerful for the small water volume. The moment it is on, it releases too much energy to cause the temperature to overshoot. Although it is still possible to stabilize the temperature with proper PID parameters, it is much easier to control if you limit the maximum output to 25%. Ideally, an optimized temperature control system should consume about 25% of the heater power at set temperature (steady state), for example, if you found out that only 50 watts of energy is needed to maintain the temperature at 60°C (141°F), ideally you should use only 200 watts heater for this job. Too much power will make the system over react too quickly. Too little power will make the system too slow in response. By using the Out function, you can make the 1400 watts heater to act as a 200 Watts heater for stable temperature control.

2) When the cooker consumes more power than controller can handle, for example, if you have a 12A, 120V AC heater and your cooker contains more than 38 Liter (10 Gallon) of water. It might take more than 90 minutes of full power heating for controller to heat up the pot. Long time of full power operation might cause the controller to overheat. You can set the output to 80%. It will prevent the controller from over heat by staying a full power too long. For details, please see Appendix 1.

Note 14. Temp Unit: You can set the display either Celsius (°C) or Fahrenheit (°F).

Note 15. Probe calibration offsets: These parameters are used to make the input offset to compensate the error produced by sensor. e.g. if the temperature displays of cabinet probe (Probe 1) is 2°C in ice water mixture, set **Probe1 Offset** = -2 will make the display to shown 0 degree. Three offset parameters are available for three probes. **Probe1 Offset** is for cabinet probe (Probe 1); **Probe2 Offset** is for food internal probe (Probe 2); **Probe3 Offset** is for Probe 3.

Note 16. Probe3 Enabled: Probe 3 Readout Option. When this option is set to “Yes”, right bottom parameter in normal display mode will show the temperature of probe 3. When this option is set to “No”, that location will show the current power output percentage instead. Please check section 3.1 for details.

Note 17. P3 ALM-TYPE: Probe 3 alarm type options. This parameter is for **Probe3 Hi Alarm** in Control Config menu. Users can set this probe 3 alarm to be absolute high alarm (ABS) or derivation high alarm reference to probe 1 reading temperature (DEV). For example, for Probe3 Hi Alarm = 300 and P3 ALM-TYPE = ABS, when probe 3 reading temperature is over 300, probe 3 alarm will be triggered. For Probe3 Hi Alarm = 10 and P3 ALM-TYPE = DEV, when probe 3 reading temperature is 10 degree higher than current pit probe reading temperature (probe 1 temperature), probe 3 alarm will be triggered.

Note 18. P3 ALM-CTL: Probe 3 alarm output control options. This parameter controls the output for Probe 3 Hi Alarm. It can be set as ALM, OUT-PAU and Both.

If **P3 ALM-CTL = ALM (Default)**, when probe 3 high alarm is triggered, the built-in buzzer will be triggered and you will see the flashing alert on the display at the same time.

If **P3 ALM-CTL = OUT-PAU**, when probe 3 high alarm is triggered, the main heater output will be disabled temporarily. Once probe 3 alarm is cleared, the main heater output will be resumed. Even you press down arrow key to mute the alarm, main heater output will still be disabled until the probe 3 alarm is cleared.

If **P3 ALM-CTL = Both**, when probe 3 high alarm is triggered, the built-in buzzer will be triggered and you will see the flashing alert on the display at the same time. Also, the main heater output will be disabled temporarily. Press down arrow key to mute the buzzer, but main heater output will be disabled until the probe 3 alarm is cleared.

Note 19. Step End Alarm: Step ending alarm setting. When **Step End Alarm** is set to “ON”, the buzzer will beep 4 times when each step is finished. It is useful to notify the user the cooking step is finished. User can turn it off if no buzzer sound is wanted at the finish of each step.

Note 20. Backlight Level: LCD backlight level setting. The higher the value, the brighter the LCD display. 0 is lowest brightness. 10 is highest brightness.

Note 21. BUZZ: Built-in buzzer option. By default, built-in buzzer is enabled when alarm is triggered (BUZZ = ON). To turn off built-in buzzer, change BUZZ to OFF.

Note 22. Data Interval: Data Logging Sampling Interval. This parameter controls the temperature sampling interval, which will be used for data export function and plot display on Aubersmart app. The controller will store 5 data traces in total: SV, Probe 1 reading (cabinet), Probe 2 reading (food probe), Probe 3 reading and the output power

percentage. Each trace can store up to 300 data points. The temperature plot of the Aubersmart App has two scales. One can display the latest 300 data points and other can display the latest 120 data points. The default setting of Dwell time is 1 minute per sample. At this setting, 300 minutes (or 5 hours) of data points can be stored. User can display the plot in either 5 hours or 2 hours. The dwell time can be set in the range of 1 minute to 5 minutes. Table 4 shows the available plot scales for the corresponding dwell time.

Table 4. Available options for Data Interval.

Data Interval Option (Interval time per sample)	Maximum Logging Time	Plot Display Option
1-minute	5-hour	2-hour/5-hour
2-minute	10-hour	4-hour/10-hour
3-minute	15-hour	6-hour/15-hour
4-minute	20-hour	8-hour/20-hour
5-minute	25-hour	10-hour/25-hour

Note: Once the data interval time is set, the app can only display the temperature plot in the two scales listed in the table. If you want to change the dwell time in the middle of cooking, you will lose all the data logged before the change. If you want keep the data, you should export the data before change this setting.

Note 23. nFit: Power line digital filter. This filter is for rejecting the power line interference. There are three settings: “Auto” for auto-detect mode (default), “A” for 50 Hertz interferences and “B” for 60 Hertz interferences. If you encounter fast fluctuating temperature reading issue, you can change this setting to “A” or “B” manually, based on your local power line frequency.

Note 24. Password: Device access password. This parameter is used to lock the access to parameter settings on Aubersmart app. Default password is 777.

Note 25. Factory Reset: Factory reset. This function will restore all the parameters (including all the stored recipe settings in the memory) back to the factory default values. This setting will not reset the WiFi configuration. To reset the WiFi setting on the controller, please press and hold SET key and TIME key for 5s, until the blue WiFi indicator starts to blink.

8. Important consideration for better control results.

The following is a list of things that could affect the result of temperature control.

a) The smoker and controller location. The smoker should not be placed directly in the sun. Direct sun light can heat the smoker to above 140 °F in the summer time, making controlling the temperature at 140 °F impossible. This is especially the problem for the black color smoker. The controller should be placed away from direct sun light also.. Users should also avoid exposing the controller to water and rain, which could damage the controller.

b) Low temperature control. The control result for temperatures below 125 °F will not be as accurate as for higher temperatures when the smoker generator is on. This is because there are two heaters in the smoker tower. One is the smoker heater controlled by the PID controller. The other is the heater from the generator that is not controlled. Our test shows that the heater in the generator itself can raise the temperature of the smoker tower by 60 °F (2 hours, in the shade with damper open). That means when the ambient temperature is at 70 °F, the smoker can be heat up to 130 °F in 2 hours by the heater of the generator (without using the heater in the smoker).

c) Damper position. Keeping the damper open will result in better temperature stability because more heat loss is created. This is important when the temperature is set below 140 °F. When the damper is closed, the temperature will take longer time to drop if it is overshoot during initial heat up. At higher temperature, closing the damper will not affect the performance much because the heat loss from the wall of the tower is increased. Close the damper at high temperature will keep the moisture of the food.

d) Temperature uniformity of the smoker tower. Our test shows that when the all the shelves were empty, the temperature inside the smoker tower is fairly uniform except the back half of the lowest shelf that is close to the heater. User should avoid placing the sensor too close to the heater because it does not represent the temperature of the rest area. When the shelves are filled, temperature variation might depend on how the foods were placed. The bottom shelf can become hotter if more food is placed in it to block the hot air from going up.

9. Tuning the controller

This controller is shipped with the system parameters set for the Bradley Smoker. The user should not change these parameters if you want to control a Bradley Smoker. Otherwise, if you feel that performance is not ideal, you can try to manually tune the system or run the auto-tune again. For detailed information on how to tune the controller, please read the section 10 for tuning the controller.

10. Auto-Tune

This section can be ignored if you are using the controller to control the Bradley Smoker because the controller already set for it.

The controller's most powerful feature is its ability to regulate virtually any cooker with stable temperature control. For stable temperature control the controller requires two things; (1) the controller must be set to the correct power level (see next section) and, (2) that it must be *tuned* to the cooker being used. Tuning is the process that matches the control characteristics of the controller to the heating characteristics of the cooker. The controller is said to be tuned to the cooker when its memory is programmed with values telling it how fast the cooker warms up, cools off, and how efficiently it transfers heat. For example, consider the difference between a heat lamp and a hot plate. When electricity is applied to a heat lamp it begins to heat instantaneously, and when it's turned off it stops heating instantaneously. In contrast, a hot plate may take several minutes to begin heating when electricity is applied and even longer to start cooling when electricity is turned off. But, to do this it must be programmed with the time constants. Describing how fast the heater heats when electricity is turned on and how fast it begins to cool when it's turned off. These time constants are called the *tuning parameters*.

Every type of cooker has its own unique set of tuning parameters. For the controller to heat with stability, it must have programmed with the tuning parameters for the cooker currently being used.

When Should the Controller be Tuned?

If the PID parameters we provided are not working for your liking, you can use the auto-tuning function to let the controller to determine the PID parameters automatically. Auto-tuning function (it's often known as self-tuning) can automatically optimize the PID parameters for your chosen cooking system. The auto-tuning function will heat up your cooker then let it cool down. It will repeat this heat/cool cycle several times. Based on the response time of the whole cooking system, the controller will calculate and set the PID parameters for your cooker.

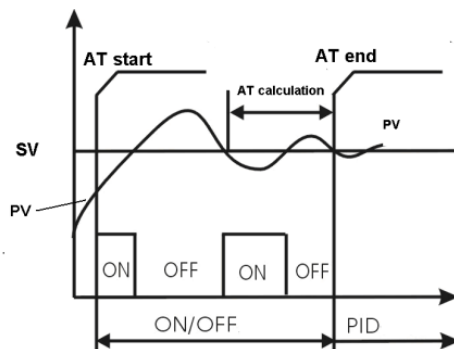

Figure 28. Auto-tune

Before using the auto-tune function, you must set the cooking equipment up in the exact configuration it will be used. For example, to tune a rice cooker, place the sensor in the room temperature pot filled with water and plug the cooker into the controller. If the cooker has its own thermostat or power control, turn both as high as they'll go. Set the controller to the appropriate power level (see next Section). Turn the controller and cooker on, and then enter the desired set point temperature closed to your normal cooking temperature.

To activate auto-tuning, enter Control Config menu. Go to parameter "Auto-tune", and set it to ON then exit the menu. the display will flash alternately between normal display and auto-tune notification (Auto-tuning Please wait...), which indicates auto-tuning is in progress. When the display stops flashing, the auto-tuning is finished. Now, the newly calculated PID parameters are set and are used for the system. The new parameters will store in the memory even the power is off.

You should always write down your old PID parameters, before letting the controller to perform auto-tuning. This way if something goes wrong, you can always go back to your old PID parameters. Or you can use factory reset feature (note 21) to reset all the parameters. The water amount in the pot should be the same volume as you would have normally used. Basically, you must setup your cooking system close to your actual cooking environment.

The duration of auto-tuning depends on how fast the system is responding to the heating and cooling cycle. If the temperature of the cooker takes a long time to drop - when heater is off- the auto-tuning could be a very long tuning process. This is especially true with a well-insulated cooker. The auto-tuning should be able to tune most of your chosen with fairly good result.

Copyright © 2021 Auber Instruments Inc. All rights reserved.

No part of this manual shall be copied, reproduced, or transmitted in any way without the prior, written consent of Auber Instruments.
Auber Instruments retains the exclusive rights to all information included in this document.

Warranty

Auber Instruments warrants this controller to be free from defects in material and workmanship for a period of one (1) year from the date of the original purchase when utilized for normal household use, subject to the following conditions, exclusions and exceptions. The sensor of the controller is warranted for 90 days.

If your appliance fails to operate properly, please contact Auber's customer support. If the appliance is found by Auber Instruments to be defective in material or workmanship, Auber Instruments will repair or replace it free of charge. A dated proof of purchase may be required.

The liability of Auber Instruments is limited solely to the cost of the repair or replacement of the unit at our discretion. This warranty does not cover normal wear of parts and does not apply to any unit that has been tampered with or used for commercial purposes. This limited warranty does not cover damage caused by misuse, abuse, negligent handling or damage due to faulty packaging or mishandling in transit. This warranty does not cover damage or defects caused by or resulting from damages from shipping or repairs, service or alterations to the product or any of its parts which have been performed by a repairperson or facility not authorized by Auber Instruments.

This warranty is available to the original purchaser of the unit and excludes all other legal and/or conventional warranties. The responsibility of Auber Instruments, if any, is limited to the specific obligations expressly assumed by it under the terms of the limited warranty. In no event is Auber Instruments liable for incidental or consequential damages of any nature whatsoever. Some states/provinces do not permit the exclusion or limitation of incidental or consequential damages and therefore the above may not apply to you.

This warranty gives you specific legal rights and you may also have other rights which vary from state to state or province to province.

*Important: Carefully pack item to avoid damage in shipping. Be sure to include proof of purchase date and to attach tag to item before packing with your name, complete address and phone number with a note giving purchase information, model number and what you believe is the problem with item. We recommend you insure the package (as damage in shipping is not covered by your warranty). Mark the outside of your package "ATTENTION CUSTOMER SERVICE". We are constantly striving to improve our products and therefore the specifications contained herein are subject to change without notice.

Appendix 1

Managing the heat generated by the controller

The heat dissipation of the controller is directly related to the electric current drawing power of the heater. If your cooker consumes less than 10 ampere of current or your pot is less than 5 gal (19 liters), you do not need to worry about the heat generated by the controller.

Sometime, the AC current requirement might not be marked on the cooking appliance. To find out how much current it will draw, divide the power (in wattage) by the line voltage, for example, an 1800 watts 120V heater will draw 15 A. A 2000 watts 240 V heater will draw 8.3 Ampere.

Why the heat becomes an issue?

The solid state relay (SSR) used in the controller is a critical component for the precision temperature control. With SSR, the power can be switched at high speed with no noise and no life time limitation. Compared with electromechanical relay, however, SSR has one drawback. It generates heat when passing the current. SSR is made of semiconductor that has a limited conductance. When passing current, the heat will be produced from the resistance. Each ampere of current will produce about 1.3 watts of heat. When 15 Amp is passing through the controller, 20 watt of heat is produced in the controller. As more heat is produced, the temperature inside the controller will rise. If it reaches to higher than 70 C, it can shorten the life or even damage some the components in the controller. The temperature inside of the controller depends on the amplitude of the current, how long the controller needs to run at full power and the ambient temperature.

The heat is only an issue during the start of the heating when the heater is running at full power. Once the temperature is close to the set point, the controller will probably need less than 50% of the power to maintain the temperature. Since the heat is directly related to the current passing the controller, the heat produced at steady state will be insignificant and can be ignored.

When the heat becomes an issue?

This controller can run at 12 A continuously without worry of the temperature of the controller. At 15A, the temperature of the controller will increase with time. The bottom of the controller where the heat sink is located can rise by 63F (35 C) from ambient if running at full power continuously for 90 minutes. For this reason we don't recommend running the controller at full power for more than 90 minutes. For 120 VAC, 15 A for 90 minute will provide enough energy to heat 10 gallon (38 liters) of water up by 108F (60 C). If you

have a pot that is bigger than 10 gallon and the heater is drawing 18 A, and you need to raise the temperature by 108 °F, you better use one of the methods mentioned below to reduce the heat in the controller. Otherwise, you might damage the controller.

Please note that when the ambient temperature is hot, as it is often the case in some commercial kitchens, the temperature of the controller will get hotter. This is because the heat dissipation is mostly determined by the temperature gradient (the temperature difference between the ambient and the controller) instead of absolute temperature of the controller itself. If the controller reaches 50 °C when the ambient is at 20 °C, it will reach 70 °C when the ambient is at 40 °C.

Solutions to reduce the heat stress on the controller.

1) Use hot water. If you fill the pot with hot water that has a temperature close to the set temperature, the heat dissipation of the controller is not an issue. As we have mentioned, once the temperature is close to the set point temperature, the controller starts to pulse (PWM) the power. The effective current is much lower, making heat not an issue.

2) Limit maximum output power. If you set output reduction parameter to 80%, then, a 18A heater will become a 14.4 A heater. It will take 25% longer time to heat up the pot, but the controller will not over heat.

In addition to these solutions, following information will also help you to manage the heat. Place the controller in right place. The SSR of Auber WS series controller is mounted in the bottom of chassis. The chassis is made of 3 mm thick aluminum for good heat dissipation. Do not cover the controller with any insulation. If you are running at 18 A with a large pot, place the controller in a well-ventilated area and tilt the instrument up with its front leg will help it to remove the heat better. However, the tilted position might allow the water to be collected at the back frame. Although the controller is splash proof, you should avoid water to be dripped to the controller when open the lid of the cooker.

Increase the P value. This can only provide limited help for reducing the heat. P is the proportional band. P=200 means the proportional band is 20.0 degrees. When the temperature is raised to less than 20 degrees from the set point temperature, the controller will start to reduce the power sooner. But if the integration time is set to very short, the controller might start to run at full power again soon.